

# AIR-4

ANALOG RADIO MIXER



 **AUDIOARTS**  
Flexible. Affordable. Built To Last.

# Audioarts AIR-4

analog radio mixer

With Audioarts' extensive experience and expertise, value engineering is a simple formula. We first carefully define the features our customers require. Design cleanly with an eye toward quality and durability. Manufacture in an efficient manner, utilizing the best of computer and machine technology.

With our Audioarts AIR-4 12-channel radio console, we've put together exactly what needs to be in a compact radio console and made it work the way it should. The AIR-4 is based upon a simple premise: Low cost does not have to be synonymous with low quality.

The AIR-4 has four microphone preamps built in. This allows the use of a host microphone and three guest microphones with the AIR-4 without the use of any external mic preamps. It gives you 12 input faders (w/A-B source select), a 13th fader for call-ins, external machine control, two program busses, built-in cue speaker and CR, headphone and studio monitoring control. Add patchable USB connectivity for PC news, production work stations or streaming audio, and the Audioarts AIR-4 is perfect for local radio stations and internet broadcasters.

The AIR-4 design utilizes top grade components and circuits for superb performance. With basic features like machine control, cue, talkback, and mix-minus included, it's perfect for smaller stations looking to upgrade as well as for larger facilities in need of an auxiliary studio or newsroom console.

The Audioarts AIR-4 mixing console draws upon Wheatstone Corporation's continuing investment in the latest design, tooling, and manufacturing infrastructure. Because we both design and manufacture our own audio consoles, right here in New Bern, NC, USA, we can ensure our reputation for unparalleled quality, performance, and reliability. The AIR-4 delivers superb broadcast quality and an excellent feature set at a great value.



- 12 stereo input fader channels, each with A and B inputs and remote START logic
- 13th phone caller fader with talkback and auto mix-minus to caller
- Four high performance mic preamps with variable gain trims to precisely match your microphones; preamp outputs jumper to any input fader's A or B input
- Two program busses with balanced outputs (switchable stereo or mono mode)
- External input feeds the monitor section (for live air or pre-delay air monitoring)
- CR room monitor switchable PGM 1, PGM 2 or external; can mute when CR mic is live
- Split cue — when any fader is in CUE, sends cue audio to left channel and L+R sum of selected monitor source to right channel (switchable separately for CR and headphone)
- Tablemount, no cutout
- RJ-45 connectors for low cost wiring
- Headphone output with built-in amplifier and concealed jack
- Dual meters: PGM 1 and PGM 2 or external
- LED switch illumination
- External power supply
- On-air light — front panel LED between the meters, and a low current closure output to drive an external ON AIR light relay.
- Studio output with independent source selection and CR-to-studio talkback button
- Plug in faders and conductive plastic monitor pots for easy replacement
- USB connection that is patchable to any of your input faders and internally dipswitchable to pick up program 1 or program 2 output mixes. Lets the AIR-4 interface with your desktop computer for news, music sweetening functions or to stream audio mixes from and to the console.
- Built-in cue speaker can automatically interrupt your main stereo monitors



# interfacing the AIR-4

modern interface for modern studios

## CONSOLE LOGIC DIPSWITCHES:

- 1) CUE TO CR - routes the cue signal to the main control room speakers for full range sound.
- 2) CR SPLIT CUE - sends the cue signal to the left CR speaker and a mono summed program signal to the right CR speaker (an internal jumper can cause the same action in the headphone circuitry).
- 3) STUDIO DIM - reduces the studio monitor signal feed level when the studio TB button is pressed.

SW4 & SW5 - when activated change Program 1 stereo output to mono (for AM stations).

SW6 & SW7 - do the same for Program 2.

## TRIM POTS:

VU METER TRIMS - separate gain trims are provided for the main program and switched VU meters for precise calibration to your facility's standards.

CALLER GAIN TRIM is provided to exactly match the signal level required by your caller interface device.

PROGRAM GAIN TRIMS provide optimal gain adjustability.

MIC GAIN - these two trimmers are used to optimally adjust the built-in mic preamplifiers to your microphones.

## USB ANALOG OUT:

May be patched to any of the console's 24 stereo RJ45 inputs, or looped to outboard processing gear. Internally dipswitchable to pick up Program 1 or Program 2 output mixes.

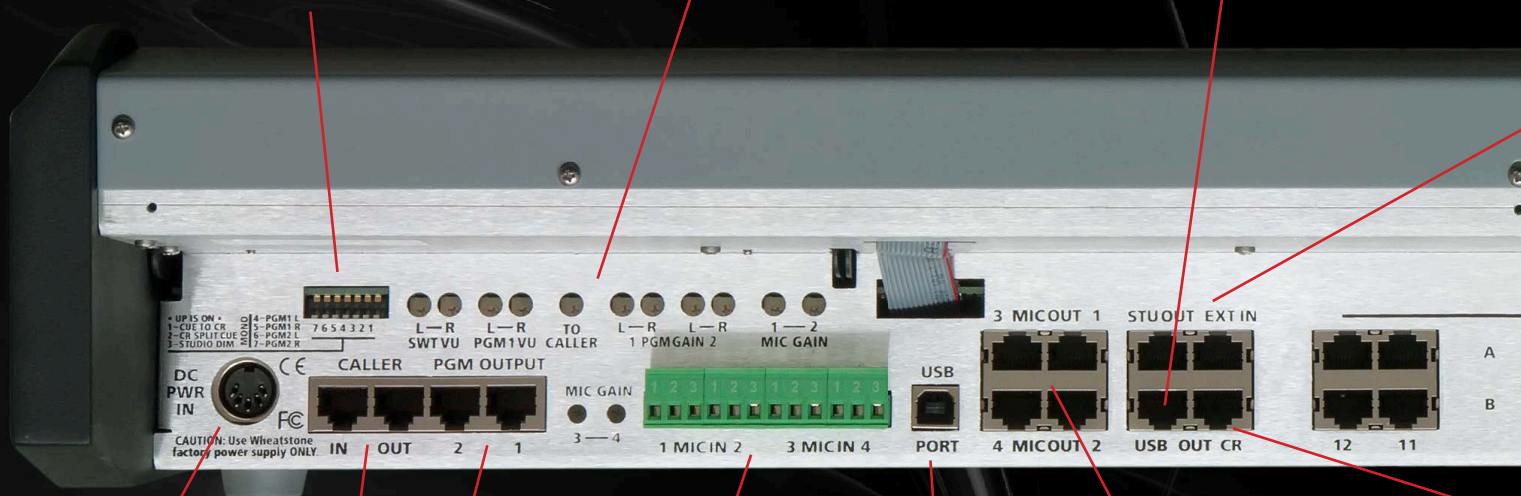

**DC PWR IN:**  
Remote power supply keeps hum and noise away from the console.

**PROGRAM OUTPUTS:**  
Separate balanced RJ45 connectors are provided for program 1 and program 2 output mixes.

**CALLER PORTS:**  
Separate input and output RJ45 connectors provide electronically balanced outputs to feed your telephone interface device.

**MIC 1 - 4 INPUTS:**  
(electronically balanced)  
A plug-in screw terminal connector accepts low level microphone signals and inputs them to the console's four microphone preamplifier circuits.

**USB PORT:**  
Lets the AIR-4 easily interface with your desktop computer for news, music sweetening functions or to stream audio mixes to and from the console.

**MIC 1 - 4 OUTPUTS:**  
The outputs of the AIR-4's low noise mic preamplifiers may be patched directly to any of the console's 13 fader channels or be connected to outboard processing gear.

The AIR-4 is THE most flexible analog mixer in its class. Its rear panel is a masterpiece of ingenuity and efficiency. Integrating the AIR-4 into your studio is a joy with its intuitive layout and accessibility. Once wired, there's a rear-panel cover to protect your work as well as make it attractive. It's the attention to detail that makes the difference.

**STUDIO OUTPUT:**

Independent studio output would normally wire to your studio guest's monitor amplifier.

**EXTERNAL IN:**

A balanced external in is available to feed either the control room or studio monitor sections. It generally would be wired to an off-air signal source.

**DB-25 LOGIC CONNECTOR:**

Provides logic ports for all 13 of your fader machine starts, on-air tally relay ports, guest TB to CR logic function, as well as a cue output for an optional external cue amplifier.

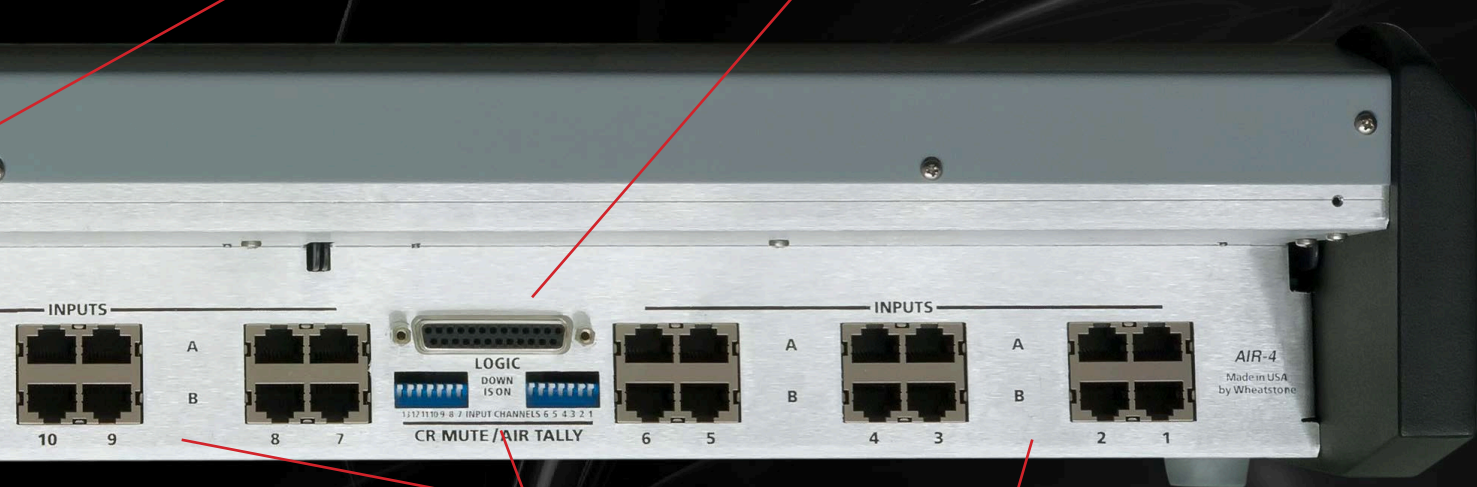

**CR OUTPUT:**

Feeds CR monitor speaker amplifier so the operator can listen to PGM 1, PGM 2 or EXT IN, or even the CUE feed if dipswitch selected (see console logic dipswitches).

**CR MUTE/TALLY:**

13 dipswitches, each associated with the console's 13 faders; when selected can cause the CR speakers to mute to prevent open mic studio feedback and also the on-air tally relay to close to warn outsiders that the studio microphone is on-air.

**INPUTS:**

The console comes with 24 stereo balanced RJ45 inputs that provide both A and B sources for all of the twelve stereo fader channels. NOTE the mic preamp outputs will automatically feed both left and right outputs when an RJ patch cord is inserted. Also NOTE the 13th phone module channel is a mono channel, but can also received a mic preamplifier input.

# using AIR-4

the features and functions you need frequently are on the control panel within easy reach

## INPUTS SECTION

### SOURCE SELECT

Selects between two analog stereo sources: A and B

### PROGRAM ASSIGN

Assign the selected source signal to any combination of the console's two stereo Program outputs

### CUE BUTTON

Places the channel's signal on the console's cue bus.

### ON BUTTON

Turns the channel on and off by means of electronic switching and can simultaneously start external source machines.

### FADER

Sets the channel's level.

## CALLER INPUT SECTION

### PROGRAM ASSIGN

Output switches assign the caller to any combination of the console's two PROGRAM outputs and permit live talk-ins.

### CUE BUTTON

Allows interviewing the caller prior to airing by including the caller's voice in the console's cue bus, where it may be heard on the meterbridge mounted cue speaker.

### TB BUTTON

When the TB switch is pressed (it is momentary action), Mic 1 will interrupt the regular caller signal, thus allowing the DJ to talk to the caller prior to airing.

### ON BUTTON

Determines if the phone channel is ON or OFF.

### FADER

Sets the caller's signal level.

## CONTROL ROOM MONITOR SECTION

### CUE LEVEL CONTROL

Determines the overall loudness of the cue signal as it appears in the console's cue speaker.

### EXT SWITCH

Pressing the EXT switch allows the operator to pick up the external input (useful for such items as tape recorders or air returns) to listen.



## PROGRAM SELECT

Pressing either of the two program switches allows the operator to listen to the selected output bus.

## CR (CONTROL ROOM LEVEL CONTROL)

Determines the overall loudness of the signal being monitored as it appears in the Control Room speakers.

## METERS SELECT BUTTONS

Select the source for the switched meter pair.

## HDPN (HEADPHONE LEVEL CONTROL)

Determines the overall loudness of the headphone output signal.

## STUDIO MONITOR SECTION

### TB (TALKBACK) BUTTON

Lets the operator's microphone signal interrupt the normal feed to the studio speakers, allowing the operator to talk to the performers in the Studio.

### EXT SWITCH

Pressing the EXT switch allows the external balanced input (such as tape recorders or air returns) to be heard in the studio.

## PROGRAM SELECT

Pressing either of the two program switches allows the selected output bus to be heard in the studio.

## STUDIO LEVEL CONTROL

Determines the overall loudness of the signal being monitored as it appears in the Studio speakers.

# inside AIR-4

flowcharts and schematics

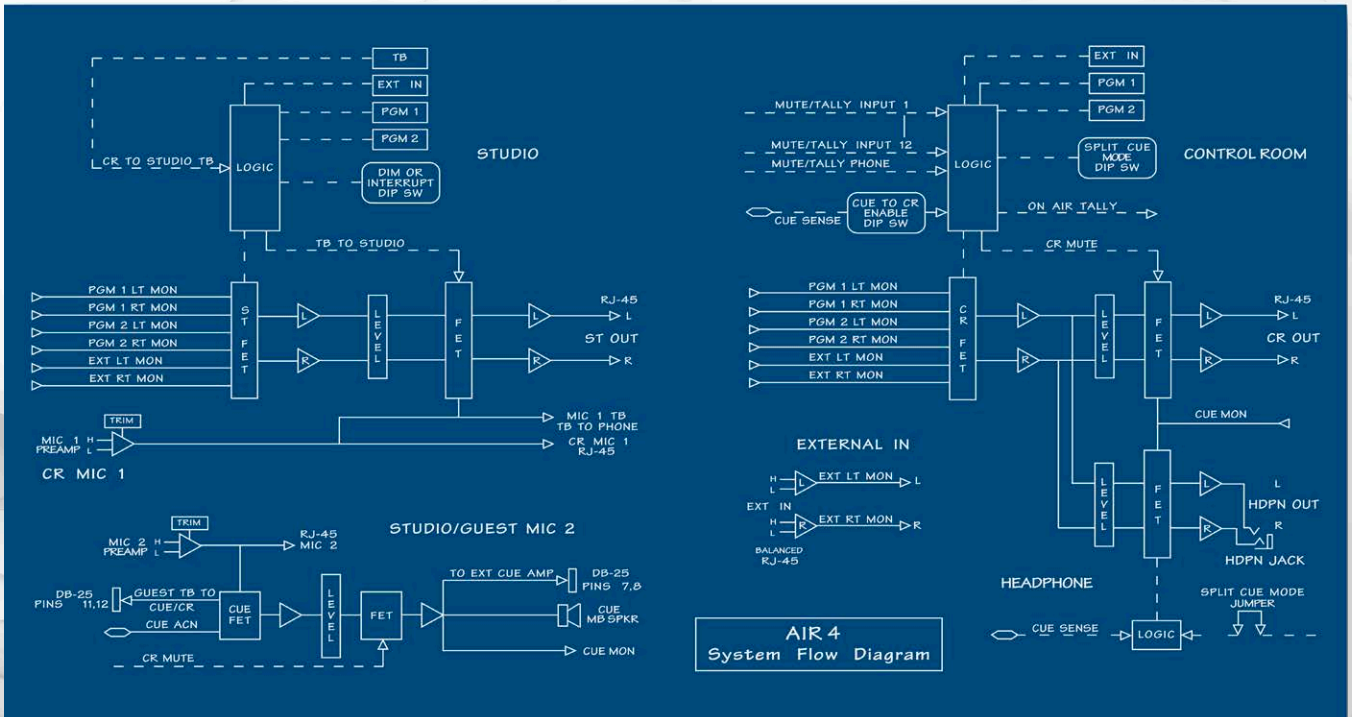
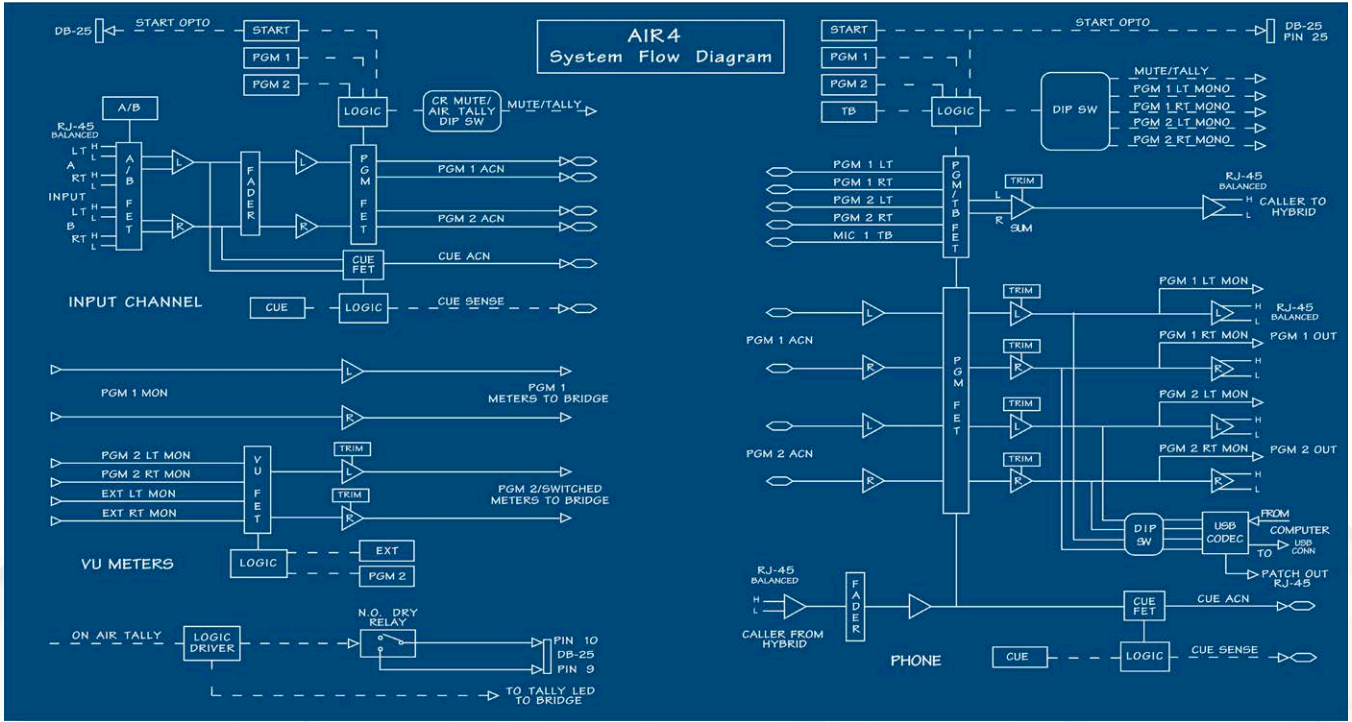

# Specifications

## AUDIO INPUT

Mic	Direct wire plug terminals, balanced Electronic differential, >2K $\Omega$ bridging Adjustable sensitivity, max. input -6dBu
Line (Caller, External)	RJ-45 balanced, >10K $\Omega$ bridging +4dBu = 0VU, max. input +24dBu

## AUDIO OUTPUT

Program & Caller	RJ-45 connectors, balanced Electronic differential, 100 $\Omega$ source Impedance to drive >600 $\Omega$ 0VU = +4dBu, max. output +24dBu
CR & Studio Monitor	RJ-45 connectors, unbalanced
Headphone	Stereo 1/4" TRS connector to directly drive typical broadcast style headphones >200 $\Omega$
Cue	Cue speaker in meterbridge DB-25 female connector output to drive external power amp

## LOGIC

On-Air	DB-25 female connector Low current closure to drive external on-air light relay
Channel Start Out	DB-25 female connector Opto-isolated output closure to remote start external devices

## PERFORMANCE

Frequency Response	$\pm$ 0.1dB 20Hz-20kHz (mic & line)
Dynamic Range	Line (unity gain) 113dB Mic (54dB gain) 100dB
Headroom	24dB above -4dB
Noise	Mic -128dB EIN Line -87dB ref 0VU
THD+N	Mic <0.02% @-50dBu in, +4dBu out Line <0.003% @-4dBu in, +4dBu out
Bus Crosstalk	-90dB @1kHz
Stereo Separation	-60dB @1kHz
Off Isolation	-115dB @1kHz

## PHYSICAL

Dimensions	28.4" / 72.1cm wide 15.4" / 39.1cm deep 4.4" / 11.2cm height (rear) 1.6" / 4.1cm height (front)
Weight	17 lbs / 7.7kg
Shipping Weight	25 lbs / 11.3kg
Power	100-240VAC / 50-60Hz / 50W

Designed and built by  
Wheatstone Corporation  
600 Industrial Drive | New Bern NC 28562-5440 USA  
phone 1.252.638-7000 | fax 1.252.635-4857  
wheatstone.com | sales@wheatstone.com



**AUDIOARTS**

Flexible. Affordable. Built To Last.